



M-11 Series

Installation and Service Manual

INTRODUCTION
SPECIFICATIONS
UNPACKING
MOUNTING
ELECTRICAL
OPERATION
MAINTENANCE
REPLACEMENT PARTS
TROUBLESHOOTING

*****IMPORTANT*****

THIS MANUAL CONTAINS PRECAUTIONARY STATEMENTS RELATING TO WORKER SAFETY. READ AND SAVE THIS MANUAL COMPLETELY AND COMPLY AS DIRECTED. ALL THE POTENTIAL HAZARDS OF DUST AND MIST CONTROL SYSTEMS AND EQUIPMENT ARE IMPOSSIBLE TO LIST; THEREFORE, OBTAIN THE SERVICES OF A PROFESSIONAL INSTALLER. A FIRE PROTECTION EXPERT SHOULD BE OBTAINED IN THE EVENT THE PRODUCT IS INTENDED FOR USE THAT PRESENTS A POTENTIAL RISK OF FIRE OR FIRE PROPAGATION. REFER TO APPROPRIATE AUTHORITIES, AND DISCUSS YOUR INTENDED USE WITH YOUR LOCAL DISTRIBUTOR OR AIR KING. WORKERS HANDLING EQUIPMENT OR SYSTEMS SHOULD BE INSTRUCTED TO CONDUCT THEMSELVES IN A SAFE MANNER.

RETAIN THESE INSTRUCTIONS FOR FUTURE REFERENCE.



SPECIFICATIONS OF THE AIR-KING M-11

Cabinet	16 GA Cold Rolled Steel
Finish	Chocolate Brown Polyurethane Chemical Resistant Paint
Size	Standard 44" L 20" W 15" H
Weight	Standard... 95 lbs CF Panel Option..... 110 lbs HEPA Option..... 125 lbs 18 lb Charcoal Option... 131 lbs Wrap A Round..... 115 Lbs
Power	115 Volt 3.5 AMPS
Capacity	Max 1100 CFM
Motor	1/5 hpPSC with thermal overload
Switch	Variable Speed Switch
Blower	9 by 9 Direct Drive Centrifugal Forward Curve
Grille	Four way individually adjustable blades
Bag Size	15" x 20" x 24" 6 pocket bag With HEPA option and 15" x 20" x 12" 6 pocket bag With 18 lb Charcoal and 15" x 20" x 12" 6 pocket bag
Prefilter	15" x 20" x 1" washable prefilter
Options	18 lb charcoal module 50% disposable charcoal filter (15" x 20" x 2") HEPA Filter Silencer Magnehelic Pressure Gage (shows when to change filters) Wrap A Round Filter
Warranty	Three years on all parts, does not include filters



SAFETY RULES

Follow all electrical and safety codes as well as the National Electrical Code (NEC), National Fire Protection Association (NFPA), and the Occupational Safety and Health Act (OSHA). Qualified personnel should perform all electrical connections and wiring only.

National Fire Protection Association (NFPA) standards require specific duct design and dust collector configuration when collecting potentially reactive metal dusts, such as aluminum, magnesium, and other materials. NFPA also covers other dusts such as grain and plastics, etc. A guideline for determining the precautions to be taken can be found in NFPA 497. Other NFPA standards may apply to your specific application. Consult current NFPA standards, available for NFPA, 1 Batterymarch Park, Quincy, MA, 02269, 800-344-3555, for applicable safeguards which may be required for the Installation, Operation, and Service of this product.

Additional references are the Uniform Building Code and the Uniform Mechanical Code.

WARNING

1. Avoid mixing combustible materials such as (but not limited to) buffing lint, paper / wood dust, aluminum or magnesium with dust generated from the grinding of ferrous materials. This creates a potential for fire due to the mixing of sparks and combustible materials.
2. Under no conditions should the machine operator be allowed to put lit cigarettes or any burning object into this or any dust/mist control system.
3. Installation of this unit in applications where there is a chance for heated and/or flammable materials to enter the unit should be evaluated to determine if a fire protection/extinguishing system should be installed. Federal, state or local codes, a required by organizations such as NFPA and Factory Mutual Insurance or your insurance carrier may require such a system. AIR KING can offer basic guidelines for such an installation; however, **final installation design is the responsibility of the filtration unit Owner/User.**
4. Explosion relief vents are required on some applications. Consult with an insurance underwriter or an NFPA manual to determine proper vent size ratio. Dust or mist collectors must be located outdoors unless otherwise indicated by NFPA standards. Dust and mist collectors **DO NOT CONTAIN EXPLOSION RELIEF VENTS** as shipped from the factory and must be field installed per NFPA standards.

**ALWAYS USE AIR KING REPLACEMENT FILTERS & PARTS TO MAINTAIN WARRANTY.
TO ORDER REPLACEMENT PARTS: CONTACT LOCAL DISTRIBUTOR.**

AIR KING LIMITED WARRANTY

Air King warrants all products sold, only to purchasers for use in business or for resale, against defects in workmanship or materials under **normal use** for three years after date of purchase from Iowa Distributing Co. Inc. This three year warranty does include standard warranties from purchased parts such as blowers, motors, valves, etc. All purchased items will fall under the manufacturers' standard warranty. Any part which is determined to be defective in material or workmanship and returned to Iowa Distributing Co. Inc. or authorized service facility, as Iowa Distributing Co. Inc. designates, shipping cost prepaid, will be, as the exclusive remedy, repaired or replaced, at Iowa Distributing Co. Inc. option. Any liability for consequential and incidental damage is expressly disclaimed. Iowa Distributing Co. Inc. liability, in all events, is limited to and shall not exceed, the purchase price paid.

Title and risk of loss pass to buyer on delivery to the common carrier. If product is damaged in transit, recipient must file claim with carrier. Iowa Distributing Co. Inc. will make a good faith effort for prompt correction or other adjustments with respect to any product that proves to be defective within the warranty period.

DISCLAIMER

Although instructions and recommendations are included for installation or your mist or dust collector equipment, the manufacturer does not assume responsibility for the installation of this equipment nor shall be held liable for direct or consequential damages resulting from improper methods, structural failure or inadequate supports.



SAFETY

READ AND SAVE THIS MANUAL COMPLETELY AND COMPLY AS DIRECTED. THIS MANUAL CONTAINS PRECAUTIONARY STATEMENTS RELATING TO WORKER SAFETY. WORKERS HANDLING EQUIPMENT OR SYSTEMS SHOULD BE INSTRUCTED TO CONDUCT THEMSELVES IN A SAFE MANNER. ALL THE POTENTIAL HAZARD OF DUST AND MIST CONTROL SYSTEMS AND EQUIPMENT ARE IMPOSSIBLE TO LIST. THEREFORE, OBTAIN THE SERVICES OF A PROFESSIONAL INSTALLER. A FIRE PROTECTION EXPERT SHOULD BE OBTAINED IN THE EVENT THE PRODUCT IS INTENDED FOR USES, WHICH PRESENT A POTENTIAL RISK OF FIRE OR FIRE PROPAGATION. REFER TO APPROPRIATE AUTHORITIES, AND DISCUSS YOUR INTENDED USE WITH YOUR LOCAL AIR KING DISTRIBUTOR OR AIRLOW MACHINE CONCEPTS.

Initial Inspection

If your new Air King units were shipped in by truck you should inspect the carton for damages or possible shortages. If there are any signs of possible shipping damages, unpack the units and make a note of the shortage or damage on the freight bill before signing it. If the carton is opened at a later time and there is damage to the unit, you should file a concealed damage claim with the delivery carrier. They are responsible for any damages in shipment or shortages that were actually shipped.

Installing Your New AIR KING Units

Installation instructions should be furnished by your dealer. All installations must meet all electrical or mechanical building codes that may apply in your particular area. If there are no local requirements, you should follow the National requirements.

All chains, hooks, bolts or other items used in the installation must be at least strong enough to support FOUR times the weight of each unit. Unit weights are as follows:

- Air King M-11..... 95 lbs
- Air King M-11CF..... 110 lbs.
- Air King M-11HE..... 125 lbs
- Air King M-11CC..... 131 lbs
- Air King M-11WA..... 115 Lbs

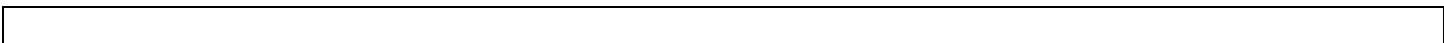

There are different ways to install your units. The most common method of installing the units is to support them from the ceiling structure with four chains. If you are going to use this method, you should drill 4 holes down through the top of the unit approximately 6” in from each end and 1” in from each side of the unit. Use at least 5/16” eyebolts with nuts and washers both inside and outside of the unit. The top end of the chains must be secured to the ceiling structure in a safe and acceptable manner. Be sure your unit is connected to the proper voltage (110-115VAC) and is protected by correct size fuses or breakers.

The next two pages are sketches indicating possible methods of mounting your M-11 cabinets.

Option 1 - Ceiling mounting methods

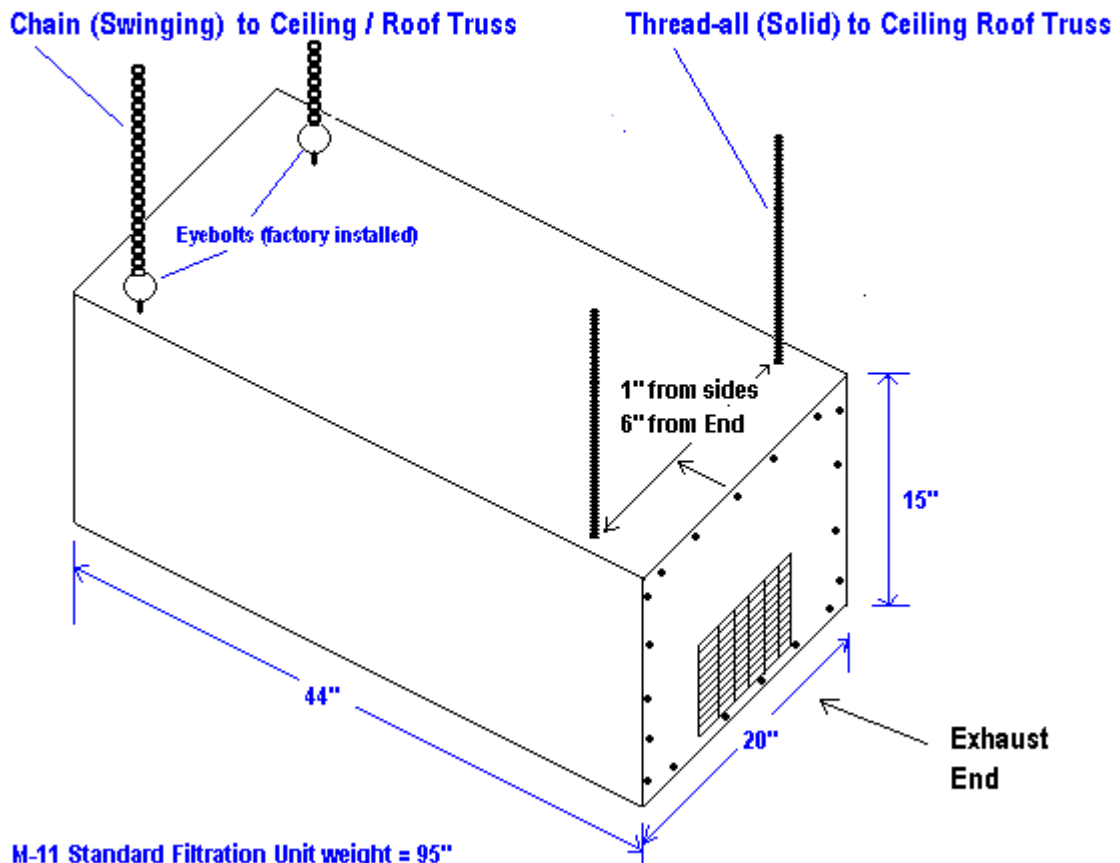

M-11 Standard Filtration Unit weight = 95"

Electrical: 115VAC Single Phase with 12' power cord drawing 3.5 Amps

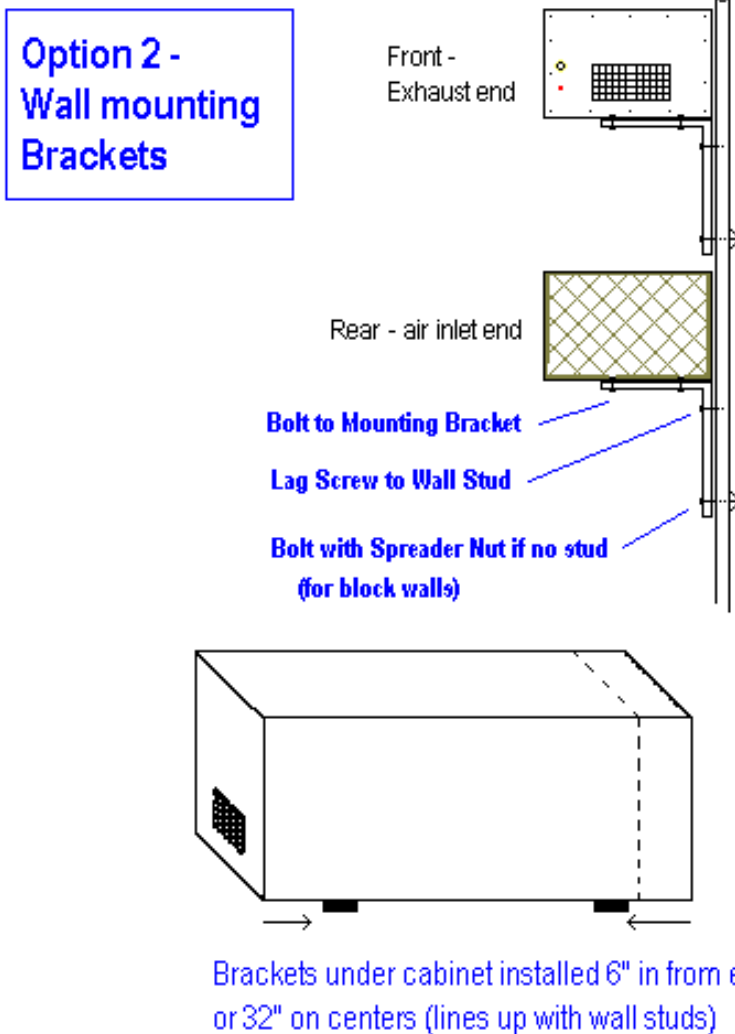

AIR KING products are designed to improve your environment. M-11 series collects dust, smoke, oil mist, oil smoke, and other atmospheric pollutants in industrial plants, shops, schools, and factories with high efficiency, 2 or 3 stage filtration. It is a complete air filter packaged unit that can be installed easily and used as a free hanging air filter unit to clean the ambient pollutants, smoke and haze.

The Air King M-11's consists of a 1" foam prefilter that traps dust and larger particles. The second stage, micro-glass multi-pocket bag filter has 98% arrestance and 95% efficiency on the atmospheric dust spot test, removing smoke and other submicron size particles from the air. Changing out the filters is easy as it requires no tools. The 1" foam prefilter pulls from the unit and can be washed. The foam prefilter can be used several times before needing replacement. Allow the foam filter to air dry for best results. The main filter is located directly behind the 1" foam prefilter and pulls out also. For light odors, there is an optional 2" 50% bypass charcoal filter available.



MOTORS

All direct drive motors are protected with automatic restart overload protection.
All belt driven units must be protected externally.

OPERATION

Do not operate your units without filter for more than a few minutes at a time.

MAGNEHELIC PRESSURE GAGE OPTION

This is an option to help determine when to change the filters. As the bags fill with contaminants, the needle on the gage will rise. We recommend changing the bags between 1.25 – 1.50 above the reading with clean filters. It is normal to change the pleated twice (or more) as much as the inside bag filter. After the pleated has been change and there is no longer a drop in pressure, then it is time to change main filter. The reading may vary depending upon the contaminants. Please consult your Sales Engineer for further information.

FILTERS

All units are equipped with replaceable type media filters. In some cases, where contaminants being picked up are dry, it is possible to wash the prefilters and reuse them. Filters are available in a number of different degrees of efficiencies. The filters in your new AIR KING unit have been selected by your representative to best collect your particular type of contaminant.

Media type filters actually become more efficient as they load with contamination. However, as the filters load up, the air flow volume will decrease and eventually will reach a point where they must be replaced to restore the original air flow. Changing the filters in your new AIR KING air cleaner is really easy. Old filters are simply pulled out of the entrance end of the unit and new filters are installed. No tools are required. Turning the unit on when installing new filters will help to pull them into place.

GENERAL NOTE: CLEANING AND INSPECTION OF CABINET

After the dirty components have been removed, inspect the cabinet interior. Remove foreign material, wipe interior, and clean all filter seating surfaces.

When installing new filters the opening in the bag filter should be in a vertical position. Be sure the cloth part of the bag does not bunch up between the bag header and the angle iron filter stops on the cabinet. Replacement filters can be supplied by your representative.

LOUVERS

Four way lovers are provided on all units to permit you to direct the discharge air away form pilot lights on heaters and to help you obtain the best air flow pattern for maximum cleaning.

PARTS

ALWAYS USE AIR KING REPLACEMENTS FILTERS & PARTS TO MAINTAIN WARRANTY.

**TO ORDER REPLACEMENTS PARTS:
CONTACT YOUR LOCAL DISTRIBUTOR, OR
THE MANUFACTURER**

IOWA DISTRIBUTING CO., INC.
1 Digital Drive
Evansdale, IA 50707

Phone (319) 266-5411

M-11 Wiring Diagram

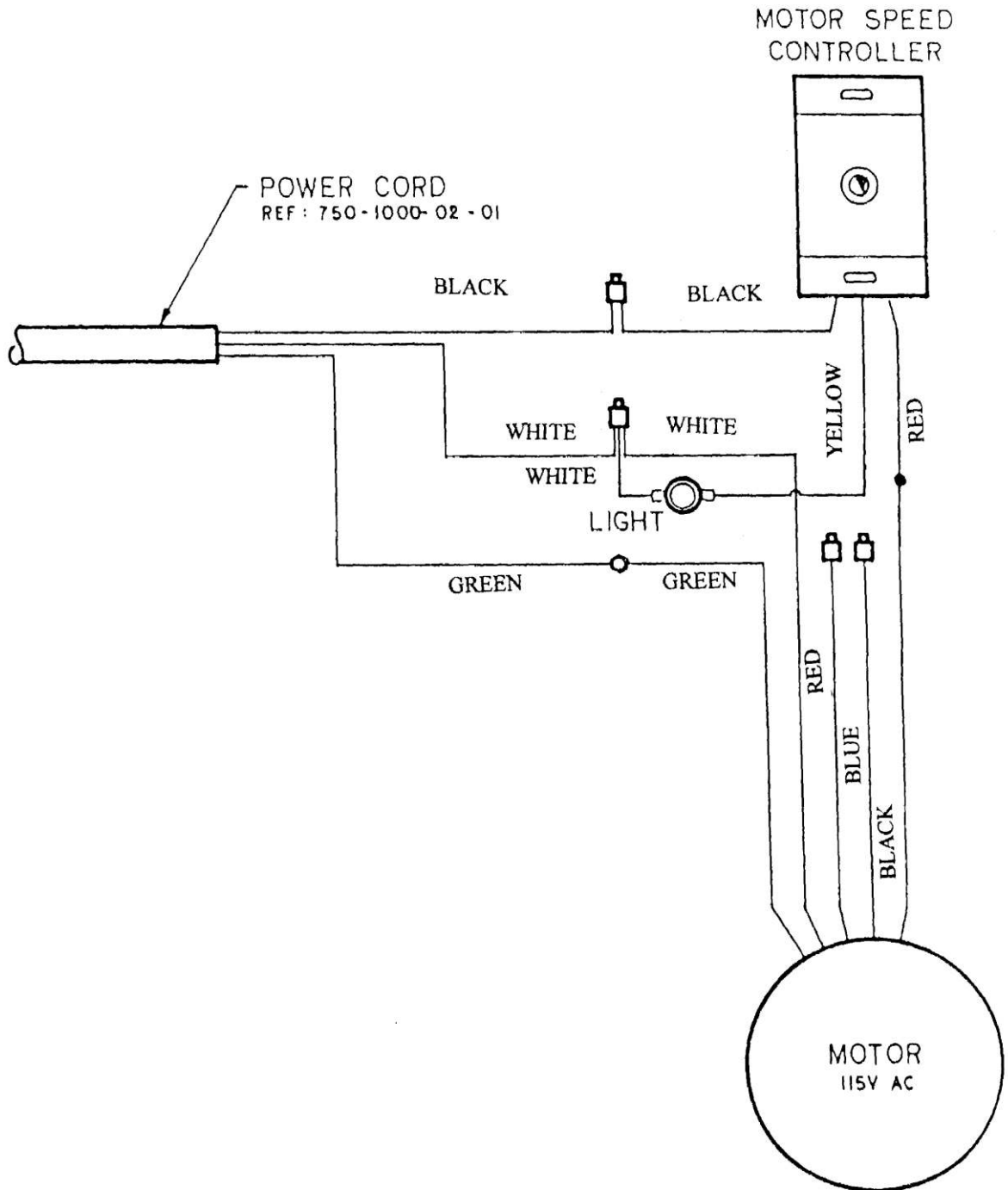

TROUBLE SHOOTING

Your  equipment has been manufactured to quality standards and tested for reliable operation at the factory. Proper operation and maintenance will result in excellent performance and longer service life.

PROBLEM	REMEDY
Motor starts with a whine and does not reach full speed.	If three phase powered, stop motor immediately . It may be "single phasing" and will overheat, possibly damaging internal windings. Check fuses and/or wires for an interruption in one of the lines. The motor may be operating on two phases only.
Motor makes a scraping or knocking noise.	Check motor cooling fan and its cover. It may have been damaged or shifted in transit and motor fan is rubbing. Check for loose blower wheel on motor shaft - tighten if necessary
No suction or pressure, or some suction but not as required (low or no airflow).	Check and open all dampers, if installed. Check ducting for blockage, if installed. Check for dirty or blocked, filters (refer to Maintenance section). Check rotation of fan.
Excess vibration.	Check structural support members. Tighten all bolts on legs and cross braces. Make sure entire structure is solid. Check for loose blower wheel - tighten if necessary.
Contaminants blowing through unit.	Check for torn or damaged filters. Check filter seals. If carbon module is used, make sure filter sock in place. Check door seals
Motor Over-amping nameplate	Access door open, close doors Incorrect Filters or no filters in the unit Ductwork faulty

If after performing the above TROUBLE SHOOTING the unit fails to perform to specifications, contact your  distributor for further assistance. In the unlikely event local help is unavailable, contact the factory for engineering assistance.

MOTOR TROUBLE GUIDE

The purpose of this guide is to suggest common answers to electrical problems. The information is not all-inclusive and does not necessarily apply in all cases. When unusual operating conditions, repetitive failures, or other problems occur, consult an electric motor service firm for assistance.

TROUBLE	CAUSE - WHAT TO DO
MOTOR FAILS TO START	<p>Blown Fuses. - Replace with time-delay fuses or circuit breakers. Check for grounded winding.</p> <p>Low voltage. - Use higher voltage tap on transformer terminals, increase wire size. Check for poor connections.</p> <p>Improper line connections. - Check connections against diagram supplied with motor.</p> <p>Overload tripped. - Check and reset relay in starter. Check heater rating against motor nameplate current rating. Check motor load. If the motor has manual re-set thermal protector, check if it has been tripped.</p> <p>Motor may be overloaded. - Reduce load. Increase motor size.</p> <p>If permanent split capacitor motor, capacitor may be open. - Indicated by humming sound. Replace run capacitor. See nameplate for correct value.</p> <p style="text-align: center;">Defective motor or starter. - Repair or replace.</p>
MOTOR STALLS	<p style="text-align: center;">Overloaded motor. - Reduce load or increase motor size. Low motor voltage. - See that nameplate voltage is maintained.</p>
MOTOR DOES NOT COME UP TO SPEED	<p>Not applied properly. - Consult motor service firm for proper type. Use larger motor.</p> <p>Voltage too low at motor terminals due to line drop. - Use higher voltage tap on transformer terminals, increase wire size. Check for poor connections.</p> <p style="text-align: center;">Load too high. - Check load motor is carrying at start-replace with larger motor.</p>
MOTOR TAKES TOO LONG TO ACCELERATE	<p style="text-align: center;">Excess Loading; high inertia load. - Reduce load. Increase motor size.</p> <p>Inadequate wiring. - Increase wire size. Check for poor connections.</p> <p>Applied voltage too low. - Reconnect to a higher transformer tap. Increase wire size. Check for poor connections.</p> <p style="text-align: center;">Defective motor. - Repair or replace.</p> <p style="text-align: center;">Inadequate starting torque. - Replace with higher horsepower motor.</p>
MOTOR VIBRATES OR IS EXCESSIVELY NOISY	<p style="text-align: center;">Motor misaligned. - Realign.</p> <p style="text-align: center;">High voltages - Check wiring connections, transformer.</p> <p style="text-align: center;">Worn, damaged, dirty or overloaded bearings. - Replace, check loading and alignment.</p> <p style="text-align: center;">Loose or defective or out-of-balance air mover. - Tighten set screw(s), repair or replace.</p>
INSUFFICIENT SPEED CHANGE	<p style="text-align: center;">Insufficient motor load. - Use a lower horsepower motor. Reduce system restrictions (blower). Increase system restriction (blower fan).</p>
MOTOR OVERHEATS WHILE RUNNING UNDER LOAD	<p style="text-align: center;">Overload. - Reduce load; increase motor size.</p> <p style="text-align: center;">Dirt preventing ventilation. - Clean motor.</p> <p style="text-align: center;">Faulty connection. - Clean, tighten or replace.</p> <p>High or low voltage. - Check voltage at motor, should not be more than 10% above or below rated.</p> <p style="text-align: center;">Defective motor. - Repair or replace.</p>